

Belt Oven
Belt Oven Systems



FLEISSNER



Function Principle

The fabric in a Fleissner belt oven is either supported by a conveyor belt or kept in place by needle chains on both sides for transportation through the oven. Nozzle boxes arranged above and below the fabric allow the heat energy to be transferred to the fabric by means of hot air applied on the through-air principle or the air-jetting principle. The air cooled down in the process is drawn in by the circulating air fan of the heating section, heated to the setpoint temperature by the heating system and returned to the fabric through the nozzle boxes. Any waste gas produced during the process is passed to the subsequent line components by the heating section exhaust fan. The required amount of fresh air is sucked in at the fabric intake. By means of nozzle boxes operating on the same principle as those in the heating section, heat energy is extracted from the fabric in the cooling section where the fabric is cooled to curing temperature. The cooling air is drawn in by the cooling section exhaust fan from the immediate surroundings through filter elements installed at the fan and operating sides and discharged to the outside through a pipe. Compression of the fabric is done by an adjustable top conveyor.

The Fleissner belt oven is used for effective, and at the same time, gentle bonding of nonwovens by means of hot air. Due to the recent increase of energy prices, Fleissner has already incorporated important features in the standard design of the belt oven to minimize energy losses.

Possible Applications for Belt Oven Lines

- Coating substrates
- Fiberfill webs
- Upholstery webs
- Rubberized coir
- Industrial nonwovens
- Geotextiles
- Nonwovens for the building industry, for thermal and acoustic insulation
- Pressed fiber parts
- Textile finishing
- Functional clothing
- Automotive nonwovens
- Shoes and synthetic leather
- Household wipes
- Medical and sanitary nonwovens

Design Versions

The air flow through the fabric in the heating section of the design version **belt oven with compaction belt and invariable flow direction** is directed exclusively from top to bottom. In the subsequent cooling section, the air flows through the product alternately from the top and the bottom. A compacting belt adjustable in height in this section allows the product to be reduced to the desired thickness.

- Belt oven with compaction belt and invariable flow direction

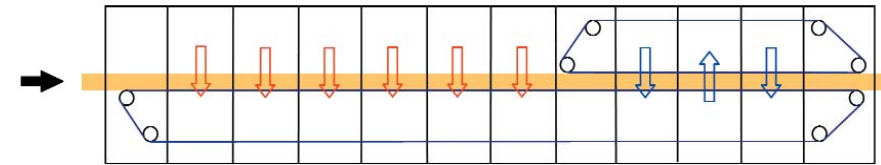

- Double belt oven with manually adjustable flow direction
- Double belt oven with variable flow direction

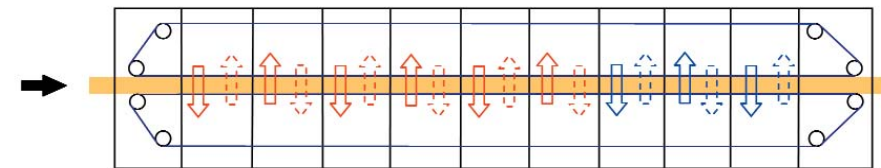

The **double belt oven** design version is provided with a bottom belt and a belt at the top which cover the entire working length (heating section and cooling section). The top belt with adjustable working height allows the product to be reduced to the desired thickness. The flow direction through the product in the heating section can be selected from top to bottom or from bottom to top and can be adjusted either manually or from the operator panel of the control system. In the subsequent cooling section, the air flows through the product alternately from the top and the bottom.

Function
Application



Belt Oven Types

Two processes, namely the **through-air principle** and the **air-jetting system**, are available for heat transfer to the fabric. The choice depends on fabric properties and air permeabilities.

When the belt oven is operated on the **Fleissner through-air principle**, the air-permeable fabric is heated very quickly and uniformly, thus supplying the heat energy required for the process.

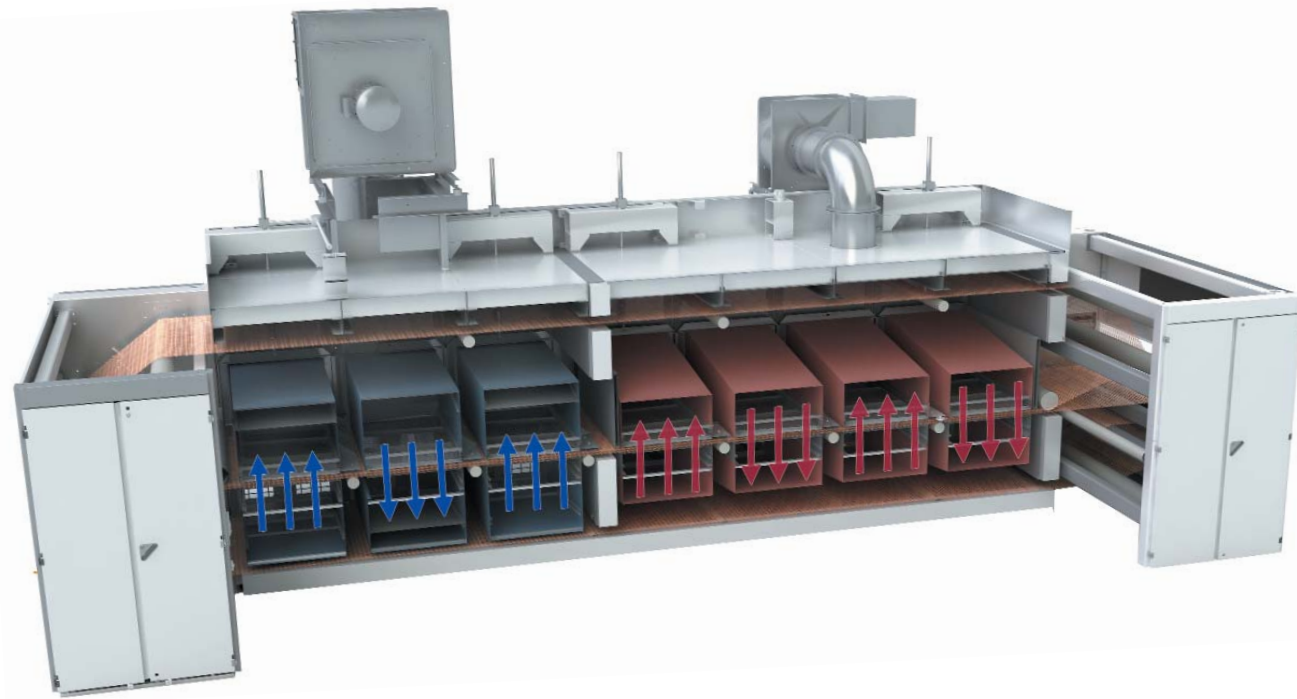

The treatment of fabrics which are impenetrable to air and permit no or only a minimum air flow through the fabric requires a process using the **air jetting system**. The product is exposed to air jets producing an air flow in parallel to the fabric surface which supplies the fabric with the heat energy required for the process.

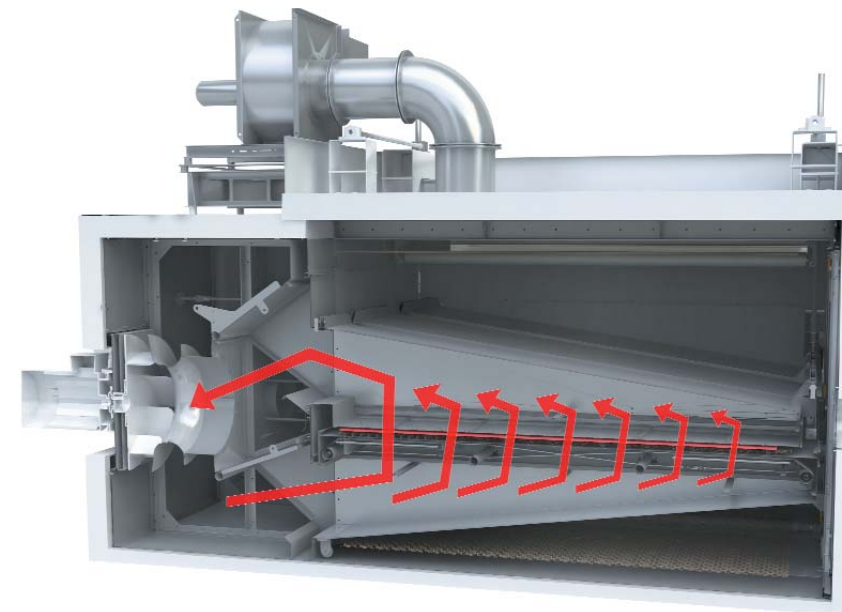
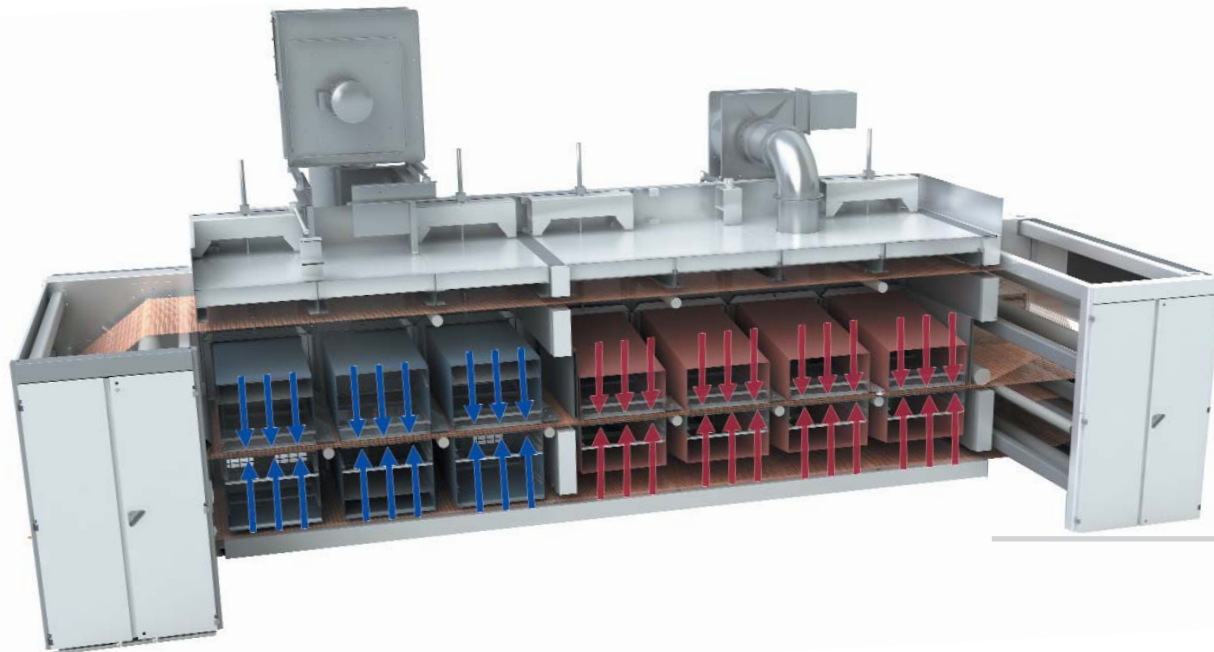

Air flow across the width of one heating zone

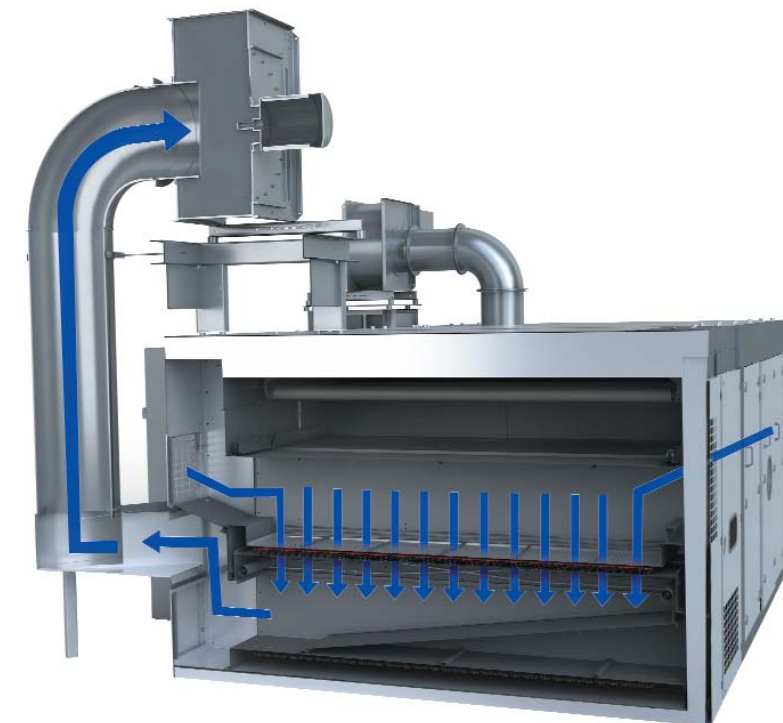

Air flow across the width cooling zone

Belt Oven

Technical Data

Nominal Working Widths [mm]:

- 2,200, 2,600, 3,000, 3,600, 4,200, 4,800, 5,400, 6,000, 6,600, 7,200
- The working width can be adapted to the product width in steps of 100 mm each by reducing the perforated width.

Product-specific Working Widths

- Adoption of working width by reducing the perforated width easily possible
- Optional electrically driven adjustment system ensures infinitely variable adaptation

Working Height Adjustment

- Clear height between top and bottom belts: 5-295 mm, option: up to 400 mm
- Height adjustment: infinitely variable, electrical adjustment from control system operator panel

Heating Section

- Temperature uniformity across the width: $\pm 1.5\%$ (for 180°C, fan capacity > 80%, working width ≤ 5 m)

Heating System Types

- Gas heating
 - Direct heating with gas burner
 - Installed heating capacity: 350/500 kW
 - Total heating capacity depends on the length of the heating zone
 - Control range: 70:1
 - Gas supply connection: 1"
 - Maximum heating temperature: 200°C
 - option: up to max. 230°C
- Oil heating
- Steam heating

Transport Belt Designs

- PTFE Kevlar transport belt
- PTFE glass fiber fabric transport belt
- PTFE glass fiber scrim transport belt
- Steel mesh transport belt
- Needle chain

Options

- Electrical working width adjustment
- Belt cleaning system
- Converter-fed fans

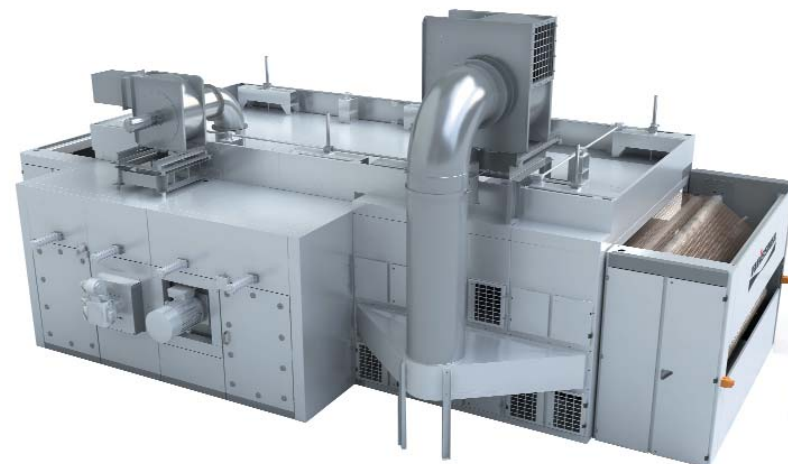
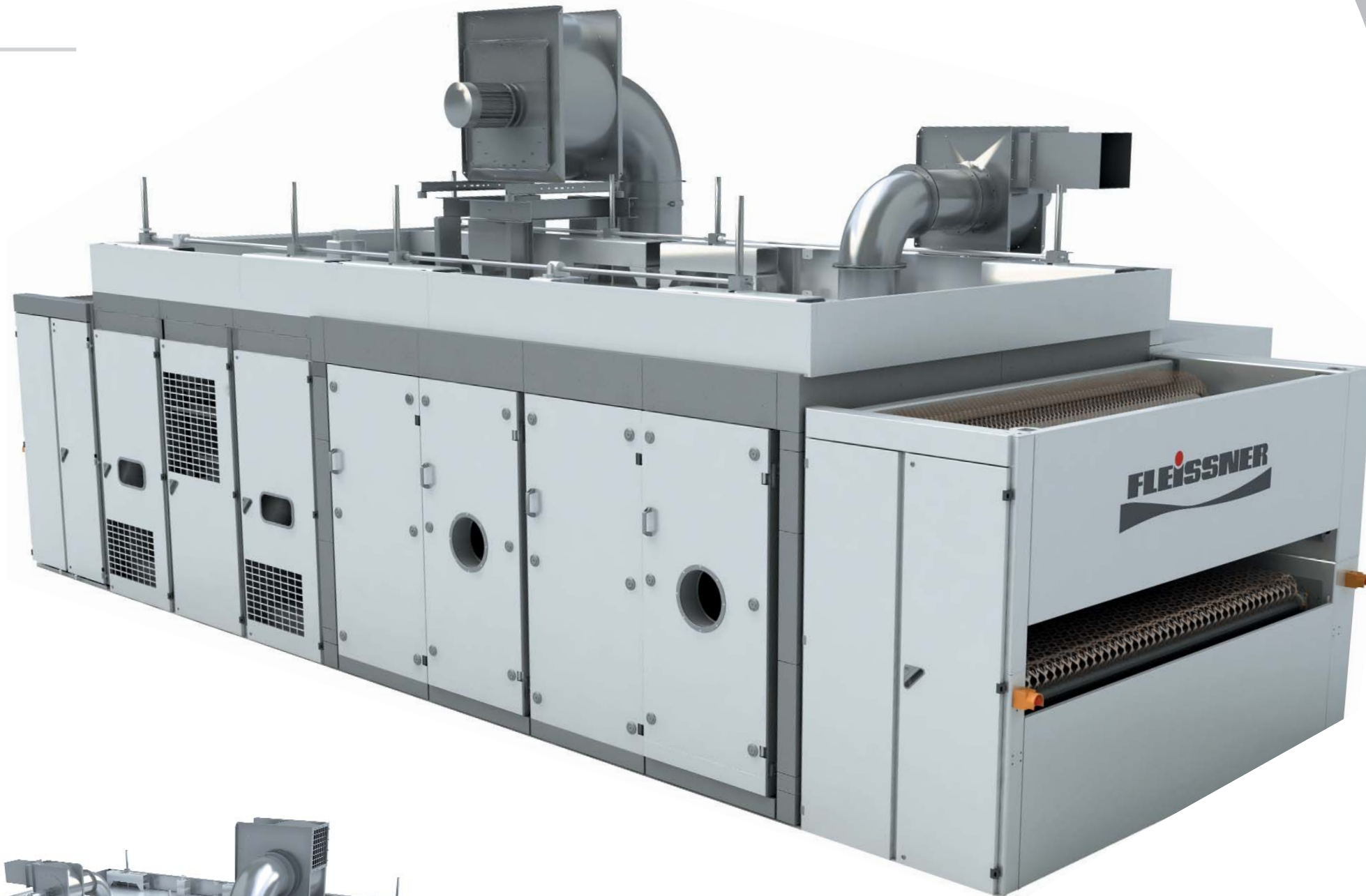

Technical Data

Advantages and Unique Selling Points

Air Guiding Systems

- Control of temperatures and fan speeds during machine standstills in line with the customer's parameter entries.
- Optimized energy consumption during operation due to a minimum supply of fresh air
- Three options of air guidance in the heating section available for double-belt ovens

Heating System

Direct gas heating with optimum thermal efficiency

- Extremely short heating-up periods
- Infinitely variable control range of 1:40
- Low-maintenance and sturdy burner design

Indirect thermal oil or steam heating

- No mixing of flue gases with circulating air
- No chemical reactions between flue gases and fabric
- Possible use of waste heat for saving of resources

Energy Consumption

- Highest energy efficiency already in standard design
- Standard: energy-saving EFF1 motors
- Energy saving by optimum air guidance
- Energy saving by optimized insulation and new door design
- Insulation of housing optimized by means of thermography

Special Design Details

- Sturdy design for a long service life
- Conveyor belt cleaning system
- Incorporation of calender and calibrating units between heating and cooling zone
- Fabric transport systems (draft-free)
- Transport conveyor of various designs, depending on application
- Needle chain for heatseating operations
- Adjustable flow direction in double-belt oven
- Prevention of energy losses by infinitely variable working width adjustment



Picture 1



Picture 2

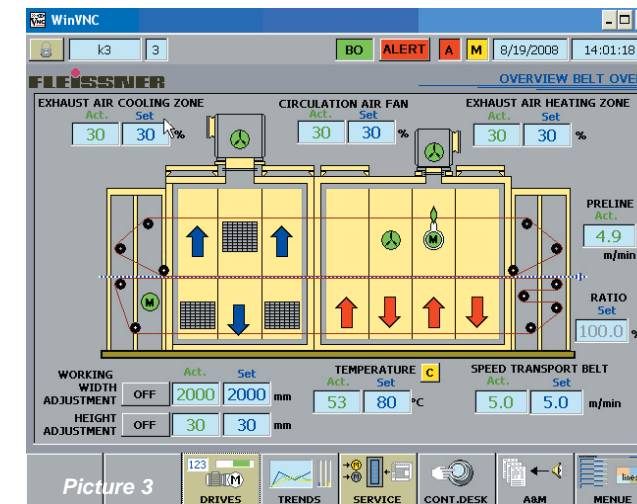

Picture 3

Maintenance

- Easy access to all maintenance units by clearly defined operating and maintenance side
- Simple cleaning of perforated plates due to drawer design (Picture 1)
- The complete working width adjustment unit can be pulled out like a drawer for maintenance work (Picture 2)
- Easy access through large maintenance doors at the operating and fan sides

Installation and Start-up

- Chamber modules ready for installation
- Low-cost delivery in standard containers
- Cost saving by minimum assembly and start-up periods at the installation site

Control and Visualization

- Simple process control with easy-to-read screen display. All relevant process data are shown in a single screen (Picture 3)
- Optimum recipe management ensures very short set-up times
- Recipes can be created, saved and loaded easily
- Remote diagnosis with high-speed internet
- Simple operation by intuitive setting and control of production processes via touch screen
- Coupling and data exchange through industrial ethernet interface allowing incorporation in all control levels

Control

Advantages

&

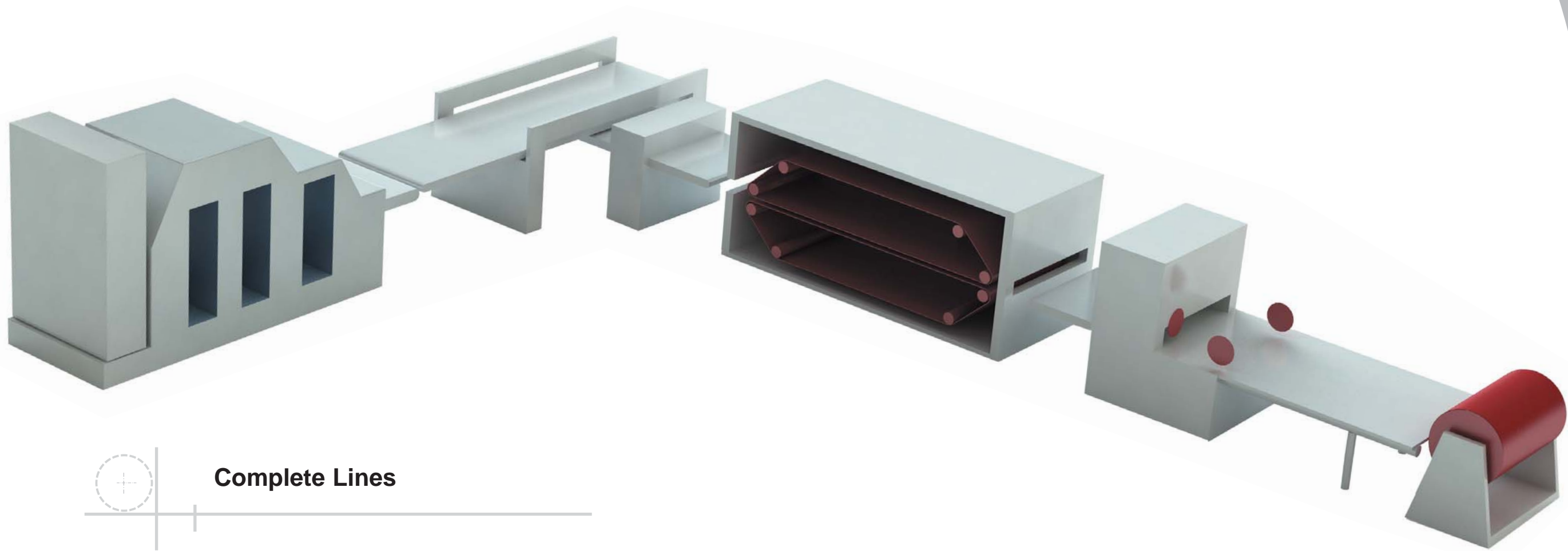

Complete Lines

Together with our sister company ERKO TRÜTZSCHLER, we deliver complete lines. ERKO's scope of supply includes fiber opening, cross-lapping and carding, FLEISSNER's scope of supply for such lines consists of the oven with heating and cooling zones as well as any other downstream machinery required for the specific application. This combination of machines from a single source is unique in the nonwovens world and guarantees smooth and trouble-free operation after a short installation period.

Lines

Complete

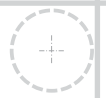

Nonwovens
Textiles
Man-Made Fibers
Paper & Tissue

Fleissner GmbH
Beijing Lufthansa Centre
Office Building
50 Liangmaqiao Road
Chaoyang District
Beijing 100125 (PR China)

Fon: +86 (0) 10-646 510-40
Fax: +86 (0) 10-646 510-42
e-mail: fbj01@263.net

Drying
Thermobonding
Heatsetting

Fleissner GmbH
Wolfsgartenstr. 6 • D-63329 Egelsbach
A company of Trützschler group
Fon: +49 (0)6103-401-0 • Fax: +49 (0)6103-401-440
e-mail: info@fleissner.de

Visit us at
www.fleissner.de

FLEISSNER